

BiZ.

BUSINESS INDUSTRY ZONE
HOMEBUSH

161 ARTHUR STREET UNIT C17 LOT 58

	gross (m ²)
ground floor area	50.00
ancillary storage	18.00
TOTAL	68.00 m²
car spaces	1.00 space

NOTE

All dimensions are approximate only.

All areas shown are gross areas. Strata plan areas will be nett areas, and will be less than the gross areas shown, as external walls, ducts stair voids, etc, will not be included.

Purchasers' attention is directed to special condition 28.9.4 of this contract, which shall prevail.

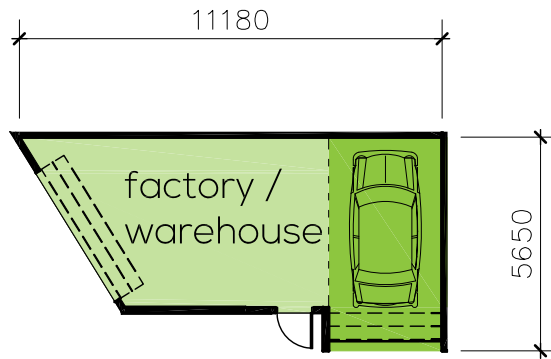

ground floor plan

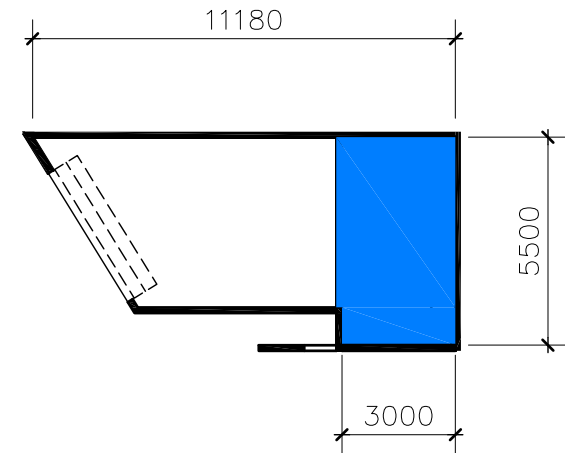

ancillary storage

